

# INYYO Q353

## User Manual

V1.9

2025/1/3

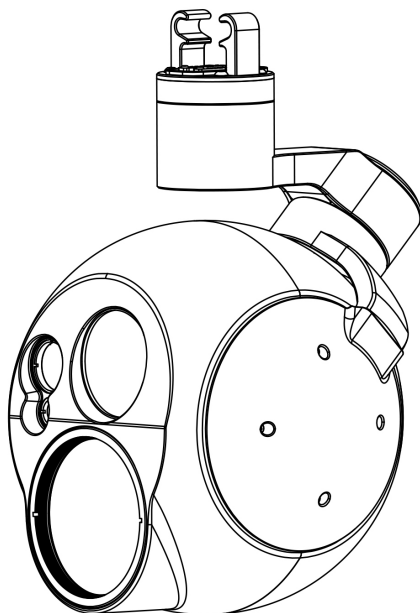

Product safety awareness is important for the safety of you, the people around you, and the environment, so be sure to read the User Manual carefully. Individual parameters of this product are updated quickly. Please refer to the latest version V1.9. The developer of this product reserves the right to interpret this document and all related documents.

### Keyword search

Electronic documents can use the search function to search for keywords. In common office software, Windows users can use the shortcut key Ctrl+F, Mac users can use Command+F to search for keywords.

### Click on the directory subtitle to jump





Users can click the subtitle in the directory to jump to the corresponding page.

### Print

This document supports low/medium/high quality printing.

## Reading Prompt

### Symbol Specification

 prohibit     Focus attention or warning     Warn     Annotation

### Disclaimer

- This product and the developer/manufacturer/distributor of this product shall not be liable for damage, injury or any legal liability arising from direct or indirect use of this product, and the user shall follow all safety guidelines including but not limited to those mentioned herein.
- This product is designed to be used only for legitimate civilian purposes and not for military purposes. Any activities conducted by the user using this product are the user's personal behavior and have nothing to do with the developer/manufacturer/distributor of this product.
- Due to the rapid replacement of this type of product, partial deviation between the final physical object and the technical parameters is a normal phenomenon.
- The developer reserves the right of final interpretation of this document and all related documents, and is subject to change without prior notice.

** Important Note**

- Please read this manual carefully before using this product and operate in strict accordance with the manual.
- Do not attempt to disassemble, modify or repair this product by yourself. Please contact the distributor if necessary.
- If you need after-sales service, please contact the dealer, see the after-sales service related content of this article for details.

## CONTENTS

Reading Prompt	2
Symbol Specification	2
Disclaimer	2
Important Note	3
Product Introduction	5
Overview	6
Technical Index	8
Main Part Description	13
Packing List	14
Mechanical Dimensions	15
Interface Definition	17
Installation Method	18
General Note	20
Product Use	21
S.BUS Channel description	22
Network Port Setting	25
Serial Port Instruction	29
After Sales Service	41
After Sales Service	42
Scope Of Non-After-Sales Guarantee	44

## Product Introduction

---

This chapter mainly introduces the functional characteristics of this product, technical indicators, the name of the main core module, and the general precautions for using this product.

[>Click here to return to Table of contents<](#)

# Product Introduction

## Overview

- The lightweight three-sensor photoelectric pod integrates SONY 30 times optical zoom starlight telephoto camera, 55mm focal length thermal imager and 3KM laser rangefinder, with AI target detection/recognition/tracking and target positioning functions as standard, providing more comprehensive operational support.
- Made of aircraft aluminum alloy CNC precision machining, high strength, rapid heat dissipation, can be started under the conditions of -20℃~60℃, with good vibration absorption, rain resistance, dust resistance, corrosion resistance, can adapt to harsh field working environment.
- The advanced dip angle triaxial stabilization PTZ has tight integration with mechanical platform, and the high-speed processor controls the motor's precise movements, achieving a high steady-state frequency to compensate for every subtle movement and maintain a stable shooting angle.
- The original intelligent mechanical design structure realizes 360 ° no blind angle rotation, can free access to unrestrained omni-directional vision.
- SONY 30 times optical zoom starlight telephoto camera, the maximum focal length up to 129mm, optical width dynamic up to 50db, whether it is day or night can easily capture distant details, clearly present the vision.
- 55mm large focal length infrared uncooled thermal camera can easily detect more distant target details, provide white heat, black heat, color palettes, obtain more recognizable thermal image pictures.
- Infrared uncooled thermal imaging detector adopts high density ceramic package, the internal metallurgical connection has stable chemical properties, up to 100 layers LTCC wiring, high mechanical strength, strong sealing, high thermal conductivity, high insulation impedance, thermal expansion coefficient and chip have extremely high compatibility, greatly increasing the service life and reliability.
- The strict optical axis parallel calibration technology can avoid the center point deviation when the near focal end is zooming to the far focal end, and the coaxiality error of the optical zoom is effectively controlled within 1%. It can

ensure that the laser ranging target is always located in the center point of the visual acquisition screen.

- INYYO 353 adopts a 22nm advanced quad-core 2.0GHZ AI chip with built-in NPU computing power up to 6.0 Tops, and has automatic detection and recognition functions for typical targets such as vehicles and personnel. Multiple targets can be detected at the same time, the target detection probability is better than 90%.
- The telephoto lens can perform high-precision real-time detection tracking or feature tracking of ground targets within visual range. During the tracking process, it can resist light changes, and target scale changes, occlusion, rotation, blur, deformation and rapid movement. It has tracking auto zoom and auto tracking based on target recognition results, it's easy to perform reconnaissance, surveillance and other tasks.
- The original 3D visual positioning system can calculate the longitude and latitude coordinates, elevation information, and distance information of the screen center point target in real-time, and transmit real-time data back through the serial port and net mouth; It has good application value in remote distance reconnaissance, precise measurement of control point coordinates, and overview of visibility areas.
- The trigger locking structure can be loaded and unloaded at high speed, which greatly increases the connection strength and enjoys the pleasant experience brought by the intelligent structure.
- The military three-proof aviation connector is used between the quick-release bracket and control module, which has safety characteristics such as high temperature resistance, corrosion resistance, vibration resistance, waterproof, electric shock resistance, anti-interference, long service life, and not easy to loosen. It can effectively prevent current leakage and short circuit, ensuring the reliability of the electrical connection.
- The special control module has multiple optimization one-click function, which makes the control experience more comfortable.



Please refer to the technical index of this paper for the actual use environment and specific parameters.

---

**Technical Index**

<b>Main parameters</b>	
Material	Aircraft aluminum alloy
Pod Size	156.5(L)*148(W)*229(H)mm
Pod weight	1849g±10g (Without controller)
Work range	-20℃~60℃
Storage range	-30℃~70℃
Protection rank	IP43
Number of axis	Triaxial (Yaw/Pitch/Roll)
Control angle range	360° ×N(Yaw); -120° ~30° (Pitch); ±40° (Roll)
Control signal	S.BUS, TTL UART, TCP、UDP
Input voltage	12V
Power	13W
Video interface	Network
Working model	Enable follow(default); Disable follow; One-click down
Control mode	Speed control; Angle control; Point to move; Target tracking
Photo format	JPG
Video storage format	MP4
Video encoding type	H.264 / H.265
Video output format	1920*1080@30fps
Storage methods	Mirco SD: 32GB (min)/512GB (max)
<b>Visible light module</b>	
Visible light pixel	2 million
Night vision level	High sensitivity mode: Color:0.009 lx (F1.6, AGC on, 1/30s) Normal mode: Color: 0.1 lx (F1.6, AGC on, 1/30s)
Optical zoom	30x
Fog penetration function	Support

Sensor	1/2.8" SONY CMOS
Focal length	4.3~129.0mm(30x)
Zoom control mode	Speed control, Multiple control
FOV (H)	64° ~2.4°
Manual recognition distance (person)	2500m
Manual recognition distance (vehicle)	7000m
AI recognition distance (person)	2000m
AI recognition distance (vehicle)	6000m
<b>Thermal Imager</b>	
Sensor	Uncooled infrared focal plane of vanadium oxide
Packaging method	High density ceramic packaging
Focal length	55mm
Resolution	1280*1024
Pixel pitch	12 μ m
Wavelength range	8~14 μ m
FOV (H×V)	16° ×12.8°
NETD	≤40mK@25℃, F#1.0
Electronic zoom	1~8x
Color palettes	black heat/ white heat/color
Manual recognition distance (person)	600m
Manual recognition distance (vehicle)	1400m
AI recognition distance (person)	400m
AI recognition distance (vehicle)	1300m

<b>Laser ranging module</b>	
Ranging range	15~3000m
Ranging mode	Continuous ranging; Single ranging
Laser wavelength	1535nm±10nm
Ranging accuracy	≤±2m
<b>AI tracker</b>	
Auto-detect target types	Typical targets like vehicles and people
Min target size	36×36 pixel
Target detection rate	≥90%
Image tracking accuracy	≤1pixel
Anti occlusion time	3s
Processing speed	≥30fps (@1080P)
Anti target deformation/occlusion	Auto
Target switching tracking	Support
Target tracking mode	Recognition tracking, Feature tracking
Tracking target selection method	Point tracking
Tracking autozoom	Support
Neural network computing power	6.0 TOPS
<b>Target localization</b>	
Positioning method	Image center point positioning (GPS information needs to be received)
Positioning accuracy	≤10m (Under non-complex terrain conditions)
Coordinate output type	Latitude and longitude
<b>Buck module</b>	
Size	50 (L)*50 (W)*20 (H) mm
Weight	56±5g
Input voltage	14-60V

Output voltage	12V
Connection method	The output terminal of the buck module (XT30 port) is connected to the control module (XT30 port), and only allows separate power supply to the pod.

■ Need to use buck module to power the pod separately; The buck module cannot power other devices, nor can it power the pod at the same time as other devices.

■ **Description of PTZ working mode**

1. Enable follow (default mode): The yaw axis of PTZ moves in real time along the horizontal direction of the current attached equipment. After the horizontal rotation of the attached equipment, PTZ will slowly correct the position of the current yaw axis in real time for about 6s, and stop after confirming the complete reset.
2. Disable follow: Lock the plane position of the current PTZ yaw axis and no longer follow the horizontal direction of the current attached equipment. This mode have temperature drift is normal phenomenon, which is generally used for surround shooting.
3. One-click down: The pitch axis of the PTZ moved to  $-90^{\circ}$  .It is used to collect orthophoto images. This function is prohibited for the upper PTZ.

■ **Description of PTZ control mode**

1. Speed control: Control the PTZ to move in a certain direction at an adjustable speed.
2. Angle control: Control the PTZ to rotate to a fixed angle, this function is limited to Instruction control.
3. Pointing movement: control the PTZ to rotate to the specified visual position based on the XY coordinates of the screen, this function is limited to Instruction control.
4. Target tracking: The automatic control PTZ stabilizes the selected target at the center point of the screen in real time. During the tracking process, the user cannot manually control it, and can exit the tracking mode after canceling the tracking.

**■ Camera zoom control mode description**

Factor control: Control the zoom of the visible light camera to a fixed multiple, this function is limited to Instruction control.

■ Manual control of the speed can be adaptive to the optical module, making it easy for users to achieve a good control experience at high magnification.

**■ Description of laser ranging mode:**

1. Continuous ranging: The laser continuously emits and receives laser, updating the laser distance in real-time; To ensure safety and working life, please keep this function turned off when not needed.

2. Single ranging: The laser emits a laser once, and after successful reception, the laser distance can be updated.

**■ Target tracking mode description**

1. Recognition tracking: The PTZ performs high-precision automatic tracking based on the detection/recognition results of typical targets already supported by AI (typical target models are trained based on the aircraft's overhead view angle, and the detection rate cannot be guaranteed under other views), and can automatically zoom according to the size of the identified target.

2. Feature tracking: The PTZ performs image feature tracking based on the user's selected non-AI recognition target.

**■ Target location function description**

After entering the specified receiving protocol, the photoelectric pod will automatically locate the center point target on the screen (required to be used below the pitch axis of  $-30^\circ$ ), and output the latitude and longitude coordinates of the target in the reply data and OSD display.

---

 Due to the rapid replacement of this type of product, partial deviation between the final physical object and the technical parameters is a normal phenomenon.

---

Main Part Description

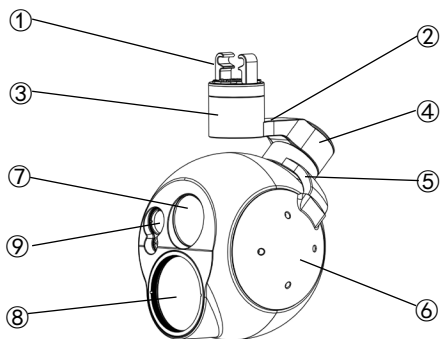

■ Pod body:

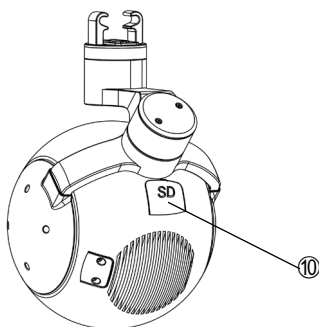

① Quick-release lug	② Yaw arm
③ Yaw electric machinery	④ Roll electric machinery
⑤ Roll arm	⑥ Pitch electric machinery
⑦ Visible light camera	⑧ Thermal imager
⑨ Laser ranging module	⑩ Card Slot

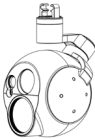
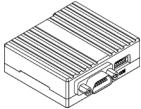

**Packing List**

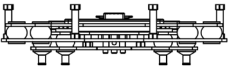
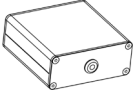
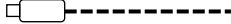
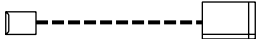
 <p>Pod body×1</p>	 <p>Controller×1</p>	 <p>Power cord×1</p>
 <p>Quick-release bracket×1</p>	 <p>Buck module×1</p>	 <p>USB-TTL×1+dupont line×1</p>  <p>Ethernet cable×1</p>

■ **Product body packing box example:**

Packing type: Air case

Inner liner: Sponge

Packing size: 360(L)×270(W)×200(H)mm

Packing weight: 3659±20g

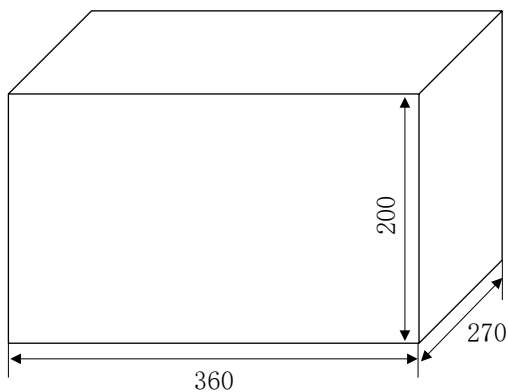

- The pod body contains a 32G Mirco SD card.
- Due to the different user's usage environment and mechanical platforms interfaces, please equip other wire rod according to the electrical interface definition in this article. Thanks for understanding!

Mechanical Dimensions (unit: mm)

■ pod body:

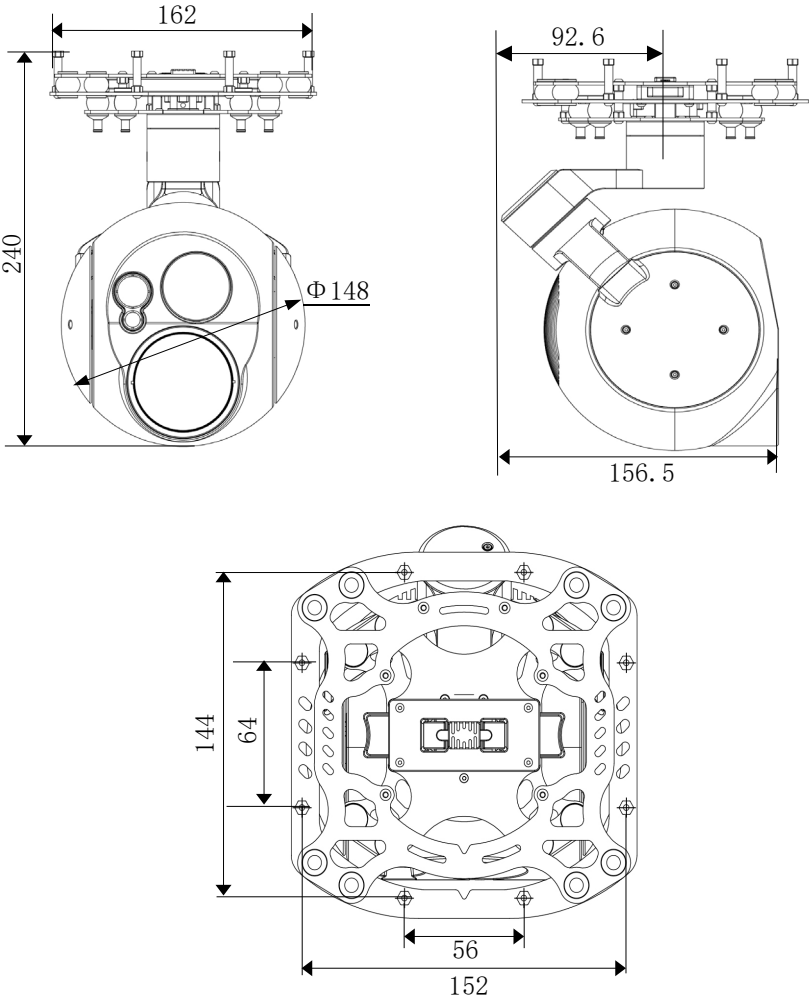

■ Quick-release bracket:

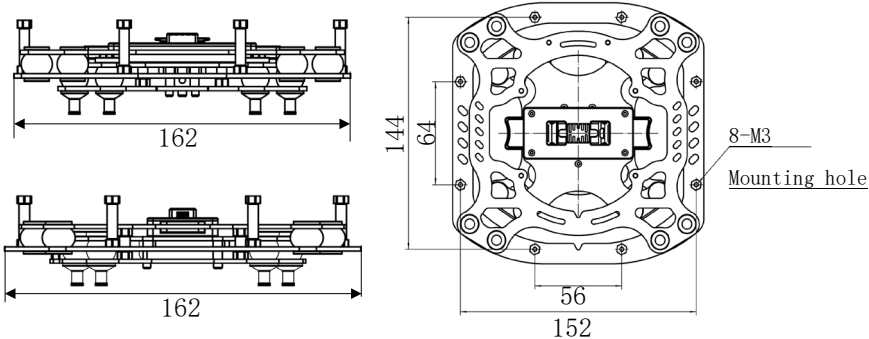

■ 12V Network port version controller(Default):

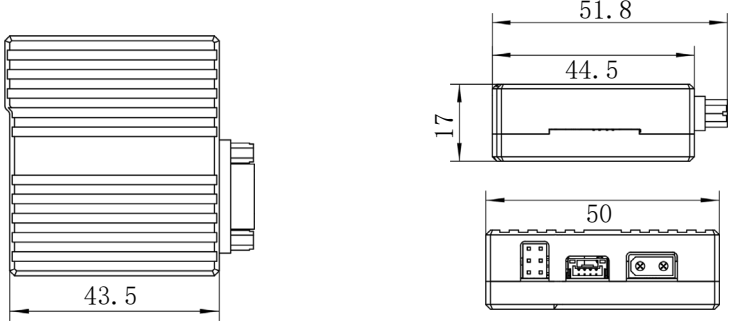

## Interface Definition

### ■ 12V Network port version controller(Default):

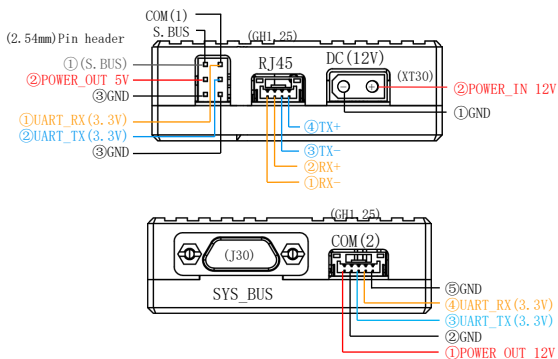

### Note

SYS_BUS	System bus, connecting quick-release bracket.
DC	12V power interface, do not input voltage beyond the supported range.
RJ45 Network Port	Connection graph/data transmission for reading video or TCP and UDP command control.
S.BUS	Connect the remote receiver for S.BUS stick control.
COM(1) (UART Serial Port)	Connect graph/data transmission or flight control, used for serial port command control and read data, default TTL.
COM(2)	Reserved serial port, does not have control function, can only receive the "data receiving protocol" of this paper.

☞ The factory default 12V single-netport output control module is standard.

# Installation Method

■ Control module and quick-release bracket:

■ The "controller" is placed inside your mechanical platform and it is recommended to use Velcro straps for fixation.

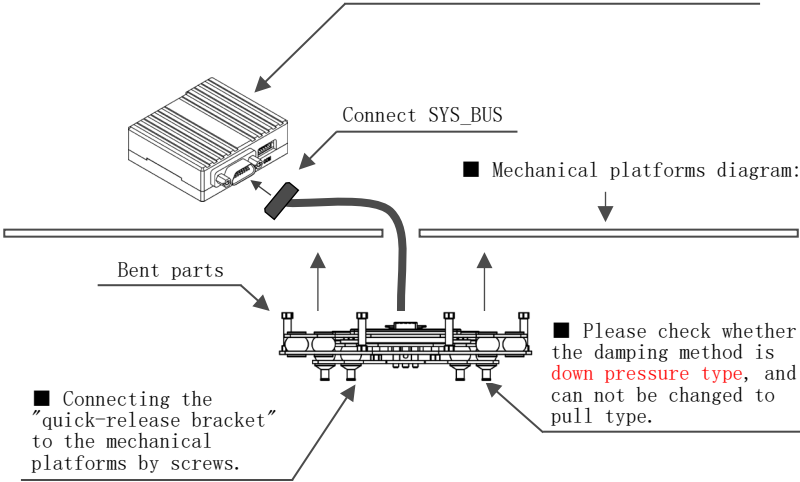

⚠ Users need to drill holes on the platform themselves to install the photoelectric pod.

■ Pod body:

■ Upper PTZ  
(It's not factory default, and should be clearly noted before purchase):

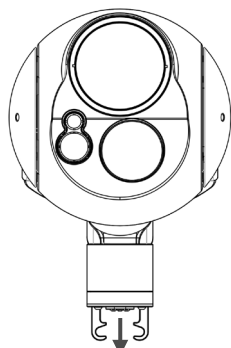

■ Quick detachable steps: Hold the "pod body" firmly by hand to prevent it from falling, press the "locking fastener" on both sides, and take out the "pod body" from "controller" at the same time.

■ Use the bottom of the platform to indicate:

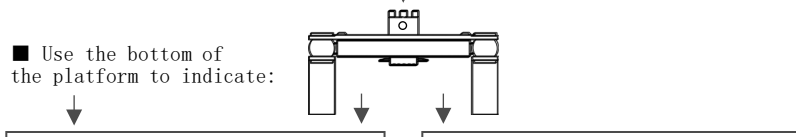

☆ Lower PTZ (factory default):

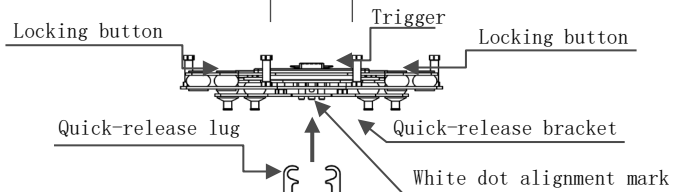

■ Quick installation steps:  
Align the white dots of the "pod body" and "controller", press the "Locking button" on both sides, insert the "pod body" into the "controller" at the same time, then release the "locking fastener", and the "pod body" is fixed.

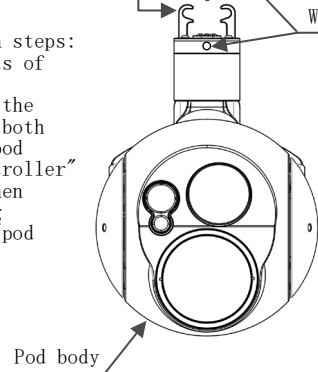

☀ The default installation method of the factory is the lower head (lifting), and the optional upper head should be clearly noted before purchase; The installation method is highly recommended to use the lower head.

## General Note

- Please confirm the **power supply voltage** in strict according to the electrical interface definition in this article. Do not input voltage beyond the supported range, otherwise the device will burn out;
- Please use the **buck module** to power the control module, confirm the **positive and negative poles of the power supply, do not connect the reverse**;
- When using battery power, please check to **make sure the battery can supply power normally(12V)**;
- When you need to control the pod through serial port, please **do not input voltage through serial port**, otherwise it will damage control board;
- When installing the vibration damping balls, please **check whether the vibration damping mode is down pressure type**, and cannot be changed to pull type, otherwise it will cause serious consequences such as falling;
- **Ensure that the PTZ remains free from obstacles at all times**. Obstructions within the PTZ operating range can impair normal functionality and may lead to serious repercussions, such as burning out the PTZ;
- **Do not increase the hood, counterweight and other items**, otherwise the PTZ will be underperforming, and even result in burning and other serious consequences;
- **Do not use thermal imaging equipment to photograph the sun**, otherwise it will burn the heat sensor;
- Do not look directly at the laser beam in the backlight with your eyes or use an optical instrument to **observe the laser beam in the backlight. No flammable objects are blocked within 20cm** in front of the laser device;
- The quick-release interface **does not support hot swapping**;
- **Do not remove the SD card during shooting or video recording**, otherwise the images obtained during the photo shooting may be lost;
- **Please keep the lens clean and wipe it with a dust-free glasses cloth**. Too dirty lens will result in slow focusing speed and even cannot focus and other consequences;
- **Do not disassemble or repair by yourself**, otherwise you will not be able to enjoy the warranty service.

## Product Use

---

This chapter describes the channel definition, network port Settings, modifying IP addresses and coding configurations, and command protocols.

[>Click here to return to Table of contents<](#)

## Product Use

### S. BUS Channel description

Channel (Default)	Function
RC_CH1 - Pitch	Up - Up
	Mid - Standby
	Down - Low
RC_CH2 - Zoom	Up - Narrow
	Mid - Standby
	Down - Enlarge
RC_CH3 - Yaw	Left - Towards the left
	Mid - Standby
	Right - Towards the right
RC_CH4 - Mode switch, one-click down	Up - Disable follow
	Mid - Enable follow (Default mode)
	Down - One-click down
RC_CH5 - Photography	Up - Take a photo
	Down - Start / stop recording
RC_CH6 - Target detection, Target tracking	Up - Target detection switch
	Down - Target tracking switch
RC_CH7 - One-click reset	Up - One-click reset
RC_CH8 - PIP, Pseudo-color switch	Up - black heat, white heat, color switch
	Down - Screen mode (PIP) switch
RC_CH9 - Laser ranging	Mid - Stop
	Down - Continuous ranging
RC_CH10 - OSD switch	Up - OSD on
	Down - OSD off



Up



Mid



Down

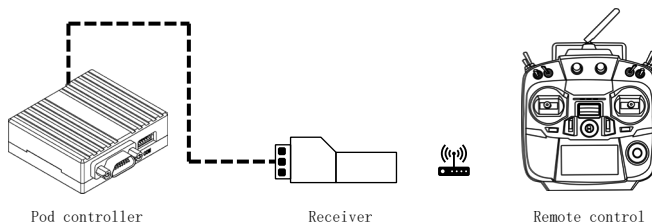

- Connect your receiver or other link transmission equipment to the S.BUS interface of the pod, and set up your remote control channels as needed;
- The rotation speed of PTZ is linear with the gear value, When the channel gear value is less than 50, PTZ will not act. It is normal that some remote controllers with lower accuracy cannot stop the movement of PTZ after the rocker returns to the center. When operating the rocker, the movement needs to slowly return to the center to avoid effectively.
- The camera can take pictures during recording.
- The pitch axis is self-stable, and the pitch angle relative to the plane position is maintained in real time.
- The working status of the yaw axis depends on the "Enable follow" and "Disable follow" modes.
- The horizontal roller is self-stabilizing and keeps the horizontal attitude in real time.

■ S.BUS channel setting instruction:

No.	Function	Byte	Note
1	Header	0xEE	
2	Message ID	0x82	
3	Frame length	0x1C	The length of all messages is 28 bytes
4	Pitch		The corresponding byte for each function represents the corresponding channel
5	Yaw		
6	Visible light zoom		
7	Visible light manual focus		



## Network Port Setting

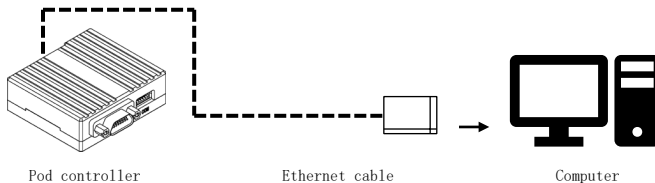

1. Take the PC as an example (you can flexibly connect other link devices based on your requirements), connect the cable to the network port of the PC, and disable the firewall.

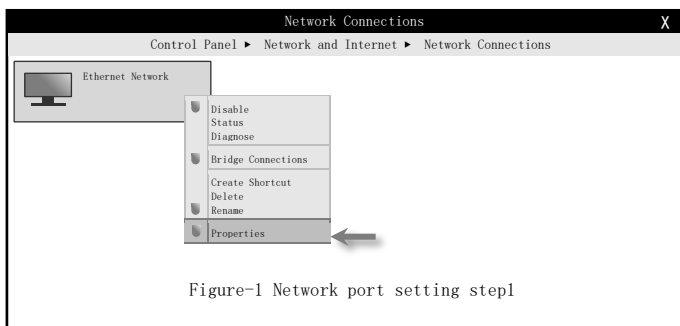

Figure-1 Network port setting step1

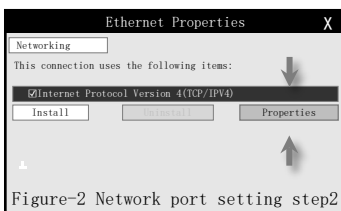

Figure-2 Network port setting step2

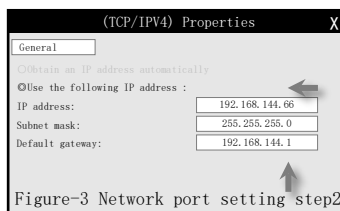
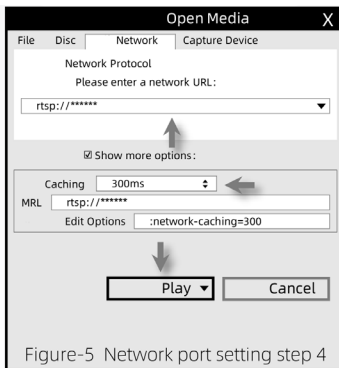

Figure-3 Network port setting step2

2. Open the “network” on your computer, select the “network and Internet settings” then select the “change adapter option”, and finally select “IPv4” in “Ethernet” to modify the computer website. Please make sure that the computer and pod are in the same network segment, as shown in the figure.

Please use the remote control with high accuracy of the lever for connection control, otherwise the function will be abnormal.

3. After setting the network segment of the computer, enter the url (default) [192.168.144.119:8554](http://192.168.144.119:8554) into the configuration interface, and you can set the video pull flow address, url, port number, compressed format (H.264/265) and bit rate.



4. Open VLC media player (Download software by yourself), Enter the pod RTSP video (default) address:

[rtsp://192.168.144.119/554](http://rtsp://192.168.144.119/554)

“Caching” input “300ms” for better video effect.

5. TCP default control port: [2000](http://2000)

**■ Modify IP address and video encoder configuration:**

① Power up the photoelectric pod normally, connect the network port to the computer, and log in to [192.168.144.119:8554](http://192.168.144.119:8554) on the browser (192.168.144.119 is the current IP address of photoelectric pod) for coding configuration.

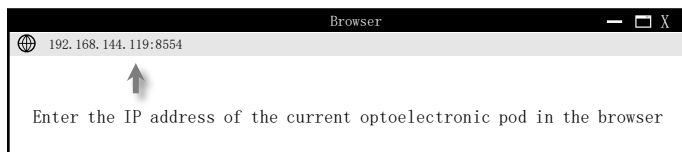

② Enter the coding configuration page, and the basic information on the configuration page is as follows:

Users need to remember the modified IP address, if you forget it, you can use “IPScan” to retrieve it.

System Setting	
System info	
Soft Version	XTA_CR21_V90002R00000B20
Device Configuration	
Camera IP	192 168 144 119 ← IP Address
Remote IP:	192 168 144 117
Camera UDP Control Port:	14551 (1~65535 except 2000)
Compression Quality:	high
HDMI Output FPS:	30
Stream Type:	H.264
Encoder Bitrate:	2048 (500~6000)
Rtmp Server Name:	Rtmp://192.168.2.117/live
Gateway:	192 168 144 1 ← IP Gateway
Web Port:	8554 (8000~9000)
RTSP Output for image transmission:	Default
Submit	

- System Info: System information

- Soft Version: Tracker current version.

- Camera IP: The IP address of this product is 192.168.144.119 by default, and the port number is 2000.

Users can freely change the address (remember not to forget), the address should be the same as the IP address network segment on the computer, if different, you need to use the computer's Ethernet address setting.

- Remote IP: The remote control address of this product.

- Camera UDP Control Port: The default is 14551.

- Compression Quality: Optional high, medium, and low, default to high.

- HDMI Output FPS: You can choose between 30 and 60, and the default is 30.

- Stream Type: H.264 and H.265 can be selected, with H.264 recording as the default.

- Encoder Bitrate: The encoding rate size defaults to 2048.

- Rtmp Server Name: default to rtmp://192.168.2.117/live.

- Web Port: Enter the webpage port number of this webpage.



- RTSP Output for image transmission: RTSP output for image transmission can be selected from "Default", "Real time Priority" and "Low fps".

- After changing the device configuration, click Submit. The page displays that after the change is successful, restart.

■ Remote download of photos/videos from web pages:

- ① Click to download videos and photos.
- ② Open photos or videos according to your needs.
- ③ When opening a photo, double-click to view it.
- ④ Open video recording: Open the video you want to download, right-click on the screen interface ->Save As, select a location, and click Save. After the browser displays that the download is complete, you can view the recorded video in the saved location.

<b>XML Upload</b>	
Upload XML File: <input type="text"/>	<input type="button" value="Browse"/>
<input type="button" value="Upload XML"/>	
<b>XML Upload</b>	
<input type="button" value="Download XML"/>	
<b>XML Upload</b>	
<input type="button" value="Download Videos or Photos"/>	
<input type="button" value="Download Log"/>	Click to download videos and photos
<b>XML Upload</b>	
<input type="button" value="Restore Factory Settings"/>	
<input type="button" value="Reboot"/>	

<b>Index of/download/</b>	
Photo/  <b>Photo Download</b>	01-Jan-1980 00:00 16K
Video/  <b>Video Download</b>	01-Jan-1980 00:00 16K

<b>Index of/download/photo/</b>	
Pic_Snap00008.jpeg	01-Jan-1980 00:00 1.4M
Pic_Snap00009.jpeg	01-Jan-1980 00:00 1.4M
Pic_Snap00010.jpeg	01-Jan-1980 00:00 1.8M
Pic_Snap00011.jpeg	01-Jan-1980 00:00 1.4M
Pic_Snap00012.jpeg	01-Jan-1980 00:00 1.2M
Pic_Snap00013.jpeg	01-Jan-1980 00:00 1.4M



3. Double click to open to view images.

<b>Index of/download/video/</b>	
Video00015.mp4	01-Jan-1980 00:00 1.3M
Video00015.srt	01-Jan-1980 00:00 16.9K
Video00016.mp4	01-Jan-1980 00:00 87M
Video00016.srt	01-Jan-1980 00:00 1.1M
Video00017.mp4	01-Jan-1980 00:00 119.4M
Video00017.srt	01-Jan-1980 00:00 1.5M



4. Open the video you want to download.

## Serial Port Instruction

### ■ Protocol format:

byte1	byte 2	byte 3	byte 4	byte 5	byte 6	byte 7
Sync byte	Address code	Instruction code1	Instruction code2	Data code1	Data code2	Check code

• Serial port or network port can be used for command control, and the serial port version controller baud rate 115200bps; The network IP address (default) is 192.168.144.119, and the port number is 2000;

- All the values in the protocol are hexadecimal;
- The instruction sync byte is always 0xFF;
- "Address code" is the logical address of the controlled equipment, address range: 0x01-0xFF;
- "Instruction code" indicates different actions;
- "Data codes" 1 and 2 represent the parameters corresponding to the pod command;
- "Check code" = byte 2 + byte 3 + byte 4 + byte 5 + byte 6;
- The "Data receiving protocol" and "S.BUS channel configuration" are only valid on the serial port.

### ■ Control instruction:

- Motion stop (instruction code 1 is 0x00, instruction code 2 is 0x00)

Example: 0xFF, 0x01, 0x00, 0x00, 0x00, 0x00, 0x01 (Stop all commands in speed control mode)

- Pitch up (instruction code 1 is 0x00, instruction code 2 is 0x08, data code 2 is motion speed, speed range 0x00-0xFF)

Example: 0xFF, 0x01, 0x00, 0x08, 0x00, 0xFF, 0x08 (in upward movement speed 0xFF)

- Pitch down (instruction code 1 is 0x00, instruction code 2 is 0x10, data code 2 is motion speed, speed range 0x00-0xFF)

Example: 0xFF, 0x01, 0x00, 0x10, 0x00, 0xFF, 0x10 (in downward movement speed 0xFF)

- Yaw left (instruction code 1 is 0x00, instruction code 2 is 0x04, data code 1 is motion speed, speed range 0x00-0xFF)

Example: 0xFF, 0x01, 0x00, 0x04, 0xFF, 0x00, 0x04 (to speed 0xFF movement to the left)

- Yaw right (instruction code 1 is 0x00, instruction code 2 is 0x02, data code 1 is motion speed, speed range 0x00–0xFF)

Example: 0xFF, 0x01, 0x00, 0x02, 0xFF, 0x00, 0x02 (to speed 0xFF movement to the right)

- PTZ left and up (instruction code 1 is 0x00, instruction code 2 is 0x0C, data code 1 is left motion speed, data code 2 is up motion speed, speed range 0x00–0xFF)

Example: 0xFF, 0x01, 0x00, 0x0C, 0xFF, 0xFF, 0x0B (in speed 0xFF movement on the left)

- PTZ left and down (instruction code 1 is 0x00, instruction code 2 is 0x14, data code 1 is left motion speed, data code 2 is down motion speed, speed range 0x00–0xFF)

Example: 0xFF, 0x01, 0x00, 0x14, 0xFF, 0xFF, 0x13 (in speed 0xFF movement under the left)

- PTZ right and up (instruction code 1 is 0x00, instruction code 2 is 0x0A, data code 1 is the right movement speed, data code 2 is the up movement speed, speed range 0x00–0xFF)

Example: 0xFF, 0x01, 0x00, 0x0A, 0xFF, 0xFF, 0x09 (to upper right movement with speed 0xFF)

- PTZ right and down (instruction code 1 is 0x00, instruction code 2 is 0x12, data code 1 is the right movement speed, data code 2 is the down movement speed, speed range 0x00–0xFF)

Example: 0xFF, 0x01, 0x00, 0x12, 0xFF, 0xFF, 0x11 (to lower right movement with speed 0xFF)

- Visible light zoom- (instruction code 1 is 0x00, instruction code 2 is 0x20, data code 1 is zoom speed, speed range 0x00–0x08)

Example: 0xFF, 0x01, 0x00, 0x20, 0x04, 0x00, 0x25 (Visible light zooms to the near end at speed 0x04)

- Visible light zoom+ (instruction code 1 is 0x00, instruction code 2 is 0x40, data code 1 is zoom speed, speed range 0x00–0x08)

Example: 0xFF, 0x01, 0x00, 0x40, 0x04, 0x00, 0x45 (Visible light is zoomed out to the far end at speed 0x04)

- Visible light zoom stop (instruction code 1 is 0x00, instruction code 2 is 0x60, data code 1 is 0x00)

Example: 0xFF, 0x01, 0x00, 0x60, 0x00, 0x00, 0x61 (Visible light zoom stop)

- Point to move (screen XY coordinates) (instruction code 1 is 0x10, instruction

code 2 is 0x00, data code 1 is X value ( $\leftrightarrow$ ), data code 2 is Y value ( $\updownarrow$ ), speed range 0x00-0ff, INYYO 46W does not support this function)

Example: 0xFF,0x01,0x10,0x00,0x40,0x40,0x91 (Point to move to the top-left 1/4 of the screen)

- Pitch angle control (instruction code 1 is 0x10, instruction code 2 is 0x01, (data code 1\*256+ data code 2) ÷ 50 are angle values (signed int16))

Example: 0xFF,0x01,0x10,0x01,0x01,0xF4,0x07 (Pitch rotated to 10 degrees)

- Yaw angle control (instruction code 1 is 0x10, instruction code 2 is 0x02, (data code 1\*256+ data code 2) ÷ 50 are angle values (signed int16))

Example 1: 0xFF,0x01,0x10,0x02,0x13,0x88,0xAE (Yaw rotation to 100 degrees)

Example 2: 0xFF,0x01,0x10,0x02,0xEE,0x6C,0x6D (Yaw rotation to -90 degrees)

- Point tracking (screen XY coordinates) (instruction code 1 is 0x11, instruction code 2 is 0x00, data code 1 is X value ( $\leftrightarrow$ ), data code 2 is Y value ( $\updownarrow$ ), speed range 0x00-0FF)

Example 1: 0xFF,0x01,0x11,0x00,0x40,0x40,0x92 (Lock the top left quarter of the screen for tracking)

Example 2: 0xFF,0x01,0x11,0x00,0x7F,0x7F,0x10 (Lock the center of the screen for tracking)

- Stop tracking (instruction code 1 is 0x11, instruction code 2 is 0x01)

Example: 0xFF,0x01,0x11,0x01,0x00,0x00,0x13 (Stop target tracking)

- Open the target detection (instruction code 1 is 0x11, instruction code 2 is 0x02, Only the photoelectric pod with AI detection, identification and tracking function supports this function)

Example: 0xFF,0x01,0x11,0x02,0x00,0x00,0x14 (Open the target detection identification)

- Close the target detection (instruction code 1 is 0x11, instruction code 2 is 0x03, Only the photoelectric pod with AI detection, identification and tracking function supports this function)

Example: 0xFF,0x01,0x11,0x03,0x00,0x00,0x15 (Close the target detection identification)

- Open test aided tracking (instruction code 1 is 0x11, instruction code 2 is 0x04, the auxiliary detection function is to use the detection ability to prevent the

loss of the target when the target tracking is blocked, and only the photoelectric pod with AI detection, recognition and tracking function supports this function)

Example: 0xFF,0x01,0x11,0x04,0x00,0x00,0x16 (Open test aided tracking)

- Close test aided tracking (instruction code 1 is 0x11, instruction code 2 is 0x05, only the photoelectric pod with AI detection, recognition and tracking function supports this function)

Example: 0xFF,0x01,0x11,0x05,0x00,0x00,0x17 (Close test aided tracking)

- Take a picture (instruction code 1 is 0x12, instruction code 2 is 0x00)

Example: 0xFF,0x01,0x12,0x00,0x00,0x00,0x13 (Take a picture)

- Start recording (instruction code 1 is 0x12, instruction code 2 is 0x01)

Example: 0xFF,0x01,0x12,0x01,0x00,0x00,0x14 (Start recording)

- Stop recording (instruction code 1 is 0x12, instruction code 2 is 0x02)

Example: 0xFF,0x01,0x12,0x02,0x00,0x00,0x15 (Stop recording)

- Enable follow (instruction code 1 is 0x13, instruction code 2 is 0x00)

Example: 0xFF,0x01,0x13,0x00,0x00,0x00,0x14 (Switch to enable follow)

- Disable follow (instruction code 1 is 0x13, instruction code 2 is 0x01)

Example: 0xFF,0x01,0x13,0x01,0x00,0x00,0x15 (Switch to disable follow)

- One-click down (instruction code 1 is 0x13, instruction code 2 is 0x02, used to collect ortho image, this function is disabled when PTZ is mounted)

Example: 0xFF,0x01,0x13,0x02,0x00,0x00,0x16 (PTZ pitch axis turned to  $-90^\circ$ , maintain vertical looking posture)

- One-click reset (instruction code 1 is 0x13, instruction code 2 is 0x03)

Example: 0xFF,0x01,0x13,0x03,0x00,0x00,0x17 (Yaw axis and pitch axis return to the middle position)

- Picture-in-picture mode switching (instruction code 1 is 0x14, instruction code 2 is 0x00, data code 1 is picture mode,0x00: visible light embedded thermal imaging,0x01: thermal imaging embedded visible light,0x02: visible light,0x03: thermal imaging, only the photoelectric pod containing a variety of optical camera modules has this function)

Example: 0xFF,0x01,0x14,0x00,0x02,0x00,0x17 (Switch to visible light)

- Thermal imaging black heat, white heat, color switching (instruction code 1 is 0x15, instruction code 2 is 0x00, data code 1 is black heat, white heat and color

switch, 0x00: white heat, 0x01: black heat, 0x02: color, only the photoelectric pod containing the thermal imaging module has this function)

Example: 0xFF, 0x01, 0x15, 0x00, 0x01, 0x00, 0x17 (Thermal imaging mode switch to black heat)

- Single ranging/Triggered Location (instruction code 1 is 0x16, instruction code 2 is 0x00, Only optical Pods containing laser ranging modules have this function. (Laser ranging pods can automatically locate targets after entering the specified protocol and ranging at the same time.))

Example: 0xFF, 0x01, 0x16, 0x00, 0x00, 0x00, 0x17 (Distance once and target location)

- Turn on continuous ranging (instruction code 1 is 0x16, instruction code 2 is 0x01, Only the photonics pod containing the laser ranging module has this function)

Example: 0xFF, 0x01, 0x16, 0x01, 0x00, 0x00, 0x18 (Turn on continuous ranging)

- Turn off continuous ranging (instruction code 1 is 0x16, instruction code 2 is 0x02, Only the photonics pod containing the laser ranging module has this function)

Example: 0xFF, 0x01, 0x16, 0x02, 0x00, 0x00, 0x19 (Turn on continuous ranging)

- Thermal imaging electronic zoom (instruction code 1 is 0x17, instruction code 2 is 0x00, data code 1 is electronic zoom multiple (1-8 times), 0x00:1 times, 0x01:2 times, 0x02:3 times, 0x03:4 times, only the photoelectric pod containing the thermal imaging module has this function)

Example: 0xFF, 0x01, 0x17, 0x00, 0x01, 0x00, 0x19 (Thermal imaging zoom to 2X)

- Turn on electronic image stabilization (instruction code 1 is 0x18, instruction code 2 is 0x00, only the photoelectric pod with AI detection, identification and tracking function supports this function)

Example: 0xFF, 0x01, 0x18, 0x00, 0x00, 0x00, 0x19 (Turn on electronic image stabilization)

- Turn off electronic image stabilization (instruction code 1 is 0x18, instruction code 2 is 0x01, only the photoelectric pod with AI detection, identification and tracking function supports this function)

Example: 0xFF, 0x01, 0x18, 0x01, 0x00, 0x00, 0x1A (Turn off electronic image stabilization)

- Turn on OSD (instruction code 1 is 0x19, instruction code 2 is 0x00)

Example: 0xFF, 0x01, 0x19, 0x00, 0x00, 0x00, 0x1A (Open screen OSD information)

- Turn off OSD (instruction code 1 is 0x19, instruction code 2 is 0x01)

Example: 0xFF, 0x01, 0x19, 0x01, 0x00, 0x00, 0x1B (Close screen OSD information)

- Turn on visible light manual focus (instruction code 1 is 0x1D, instruction code 2 is 0x00)

Example: 0xFF, 0x01, 0x1D, 0x00, 0x00, 0x00, 0x1E (Turn on visible light manual focus)

- Turn off visible light manual focus (instruction code 1 is 0x1D, instruction code 2 is 0x01)

Example: 0xFF, 0x01, 0x1D, 0x01, 0x00, 0x00, 0x1F (Turn off visible light manual focus)

- Focus the near end manually (instruction code 1 is 0x1D, instruction code 2 is 0x02)

Example: 0xFF, 0x01, 0x1D, 0x02, 0x00, 0x00, 0x20 (Visible to the remote focusing)

- Focus the distal end manually (instruction code 1 is 0x1D, instruction code 2 is 0x03)

Example: 0xFF, 0x01, 0x1D, 0x03, 0x00, 0x00, 0x21 (Restore default video streaming address)

- Manual focus Stop (instruction code 1 is 0x1D, instruction code 2 is 0x04)

Example: 0xFF, 0x01, 0x1D, 0x04, 0x00, 0x00, 0x22

- Query S.BUS channel configuration (instruction code 1 is 0x1E, instruction code 2 is 0x00, the current S.BUS channel configuration will be returned after sending)

Example: 0xFF, 0x01, 0x1E, 0x00, 0x00, 0x00, 0x1F (Query S.BUS channel configuration)

- Query movement time (instruction code 1 is 0x1E, instruction code 2 is 0x01)

Example: 0xFF, 0x01, 0x1E, 0x01, 0x00, 0x00, 0x20

- Query version (instruction code 1 is 0x1E, instruction code 2 is 0x02. Return data format: EE, 06, 0B, Version type, pod model, date, time, minute, sum check. The date is 3 bytes, and the rest are 1 bytes.)

Example: 0xFF, 0x01, 0x1E, 0x02, 0x00, 0x00, 0x21

- Specifies the return frequency of pod status information (instruction code is 0x20 0x00, data code 1 is the return frequency, 0x01 corresponds to 1Hz, 0x02 corresponds to 2Hz (default), 0x03 corresponds to 3Hz, ... 0x09 corresponds to 9Hz, 0x0A corresponds to 10Hz, and the value ranges from 1 to 10Hz)

Example 1: 0xff, 0x01, 0x20, 0x00, 0x02, 0x00, 0x23 (The return frequency of pod status information is 2Hz)

Example 2: 0xff, 0x01, 0x20, 0x00, 0x0A, 0x00, 0x2B (The return frequency of pod status information is 10Hz)

- Restore default video streaming address (instruction code 1 is 0x21, instruction code 2 is 0x00)

Example: 0xFF, 0x01, 0x21, 0x00, 0x00, 0x00, 0x22 (Only have AI detection identification tracking function of photoelectric pod to support this feature)

- Query the pull address (instruction code 1 is 0x21, instruction code 2 is 0x01)

Example: 0xFF, 0x01, 0x21, 0x01, 0x00, 0x00, 0x23 (Only have AI detection identification tracking function of photoelectric pod to support this feature)

- Turn on PTZ (instruction code 1 is 0x22, instruction code 2 is 0x00)

Example: 0xFF, 0x01, 0x22, 0x00, 0x00, 0x00, 0x23

- Turn off PTZ (instruction code 1 is 0x22, instruction code 2 is 0x01)

Example: 0xFF, 0x01, 0x22, 0x01, 0x00, 0x00, 0x24

- PTZ reboot (instruction code 1 is 0x22, instruction code 2 is 0x02)

Example: 0xFF, 0x01, 0x22, 0x02, 0x00, 0x00, 0x25

- Movement reboot (instruction code 1 is 0x22, instruction code 2 is 0x03)

Example: 0xFF, 0x01, 0x22, 0x03, 0x00, 0x00, 0x26

- Set data reply frequency (instruction code 1 is 0x20, instruction code 2 is 0x00, data code 1 is frequency, support 1-10Hz)

Example: 0xFF, 0x01, 0x20, 0x00, 0x0A, 0x00, 0x2B (Set data reply frequency to 10Hz)

- The initial movement speed of the in PTZ speed control mode is 0-45 ° /s;
- The initial movement speed of the One-click reset/One-click down, angle control, point to move function is about 300 ° /s. When approaching the specified angle, the speed will gradually decrease to complete the action;
- The angle control Instruction cannot input the angle value exceeding the working range of the PTZ;
- The default data reply frequency is 2Hz;
- After entering the specified receiving protocol, the photoelectric pod will automatically conduct target positioning.

■ Response data:

No.	Function	Byte	Note
1	Header	0xEE	
2	Message ID	0x01	
3	Frame length	0x1D	The length of all messages is 29 bytes
4	Laser ranging distance (decimeter)	Low eight	Product data without laser ranging function is 0
5		High eight	
6	PTZ roll angle (@0.1°)	Low eight	Tilting left is negative, tilting right is positive
7		High eight	
8	PTZ pitch angle (@0.1°)	Low eight	Head down is negative, head up is positive
9		High eight	
10	PTZ yaw angle (@0.1°)	Low eight	Turn right from 0 to 180 Turn left from 0 to -180
11		High eight	
12	Visible light zoom multiple (integer)		
13	Track status		0x00: Not tracked 0x01: Tracking
14	Target latitude*10000000	Low byte	Example: The actual latitude is 38.1234567, and the four byte data is 381234567
15			
16			
17		High byte	
18	longitude*10000000	Low byte	Example: The actual longitude is 114.1234567, and the data of these four bytes is 1141234567
19			
20			
21		High byte	
22	Target height (decimeter)	Low eight	
23		High eight	
24	Visible light zoom multiple (0.1x)	Low eight	
25		High eight	
26	Reserve		

27	Reserve		
28	PTZ working mode		0x00: Enable follow, 0x01: Disable follow, 0x02: One-click down
29	Sum check		1-28 bytes sum, take the lower eight bits

• Example:0xEE, 0x01, 0x1D, 0xB8, 0x0B, 0x32, 0x00, 0x3E, 0xFE, 0xE8, 0x03, 0x05, 0x01, 0x87, 0x2D, 0xB9, 0x16, 0x87, 0xDB, 0x05, 0x44, 0x7B, 0x00, 0x00, 0x00, 0x00, 0x01, 0xD8

(Laser ranging is 300m, roll angle is 5°, pitch angle is -45°, yaw angle is 100°, visible light zoom is 5x, tracking is underway, target latitude is 38.1234567, target longitude is 114.1234567, target altitude is 12.3m, and PTZ working mode is disable follow.)

■ Data receiving protocol:

No.	Function	Byte	Note
1	Header	0xEE	
2	Message ID	0x81	
3	Frame length	0x22	The length of all messages is 34 bytes
4	Aircraft (mechanical platforms) roll angle (@0.1°)	Low eight	Tilting left is negative, tilting right is positive
5		High eight	
6	Aircraft (mechanical platforms) pitch angle (@0.1°)	Low eight	Head down is negative, head up is positive
7		High eight	
8	Aircraft (mechanical platforms) yaw angle (@0.1°)	Low eight	Turn right from 0 to 180 Turn left from 0 to -180
9		High eight	
10	Aircraft (mechanical platforms) latitude*1000000	Low byte	Example: The actual latitude is 38.1234567, and the four byte data
11			
12			

13		High byte	is 381234567	
14	Aircraft (mechanical platforms) longitude*10000000	Low byte	Example: The actual longitude is 114.1234567, and the data of these four bytes is 1141234567	
15				
16				
17		High byte		
18	Aircraft (mechanical platforms) altitude (decimeter)	Low eight		
19		High eight		
20	Aircraft (mechanical platforms) relative height (decimeter)	Low eight		
21		High eight		
22	GPS time (Beijing time)	Year	Example: This byte will be 21 in 2021	
23		Month		
24		Day		
25		Hour		24-hour
26		Minute		
27		Second		
28	Aircraft (mechanical platforms) eastward speed(cm/s)	Low eight	East direction is positive	
29		High eight		
30	Aircraft (mechanical platforms) northbound speed(cm/s)	Low eight	North direction is positive	
31		High eight		
32	Aircraft (mechanical platforms) ascent speed(cm/s)	Low eight	Sky direction is positive	
33		High eight		
34	Sum check		1-33 bytes sum, take the lower eight bits	

• Example:

0xEE, 0x81, 0x22, 0x32, 0x00, 0x3E, 0xFE, 0xE8, 0x03, 0x87, 0x2D, 0xB9, 0x16, 0x87, 0xDB, 0x05, 0x44, 0xD0, 0x07, 0x7B, 0x00, 0x00, 0x00, 0x00, 0x00, 0x00, 0x00, 0x00, 0x00, 0x00, 0x00, 0x00, 0x00, 0x6A

(The aircraft (mechanical platforms) roll angle is 5° , pitch angle is -45° , yaw angle is 100° , latitude is 38.1234567, longitude is 114.1234567, altitude is 200, relative height is 12.3)

**■ Current S.BUS channel configuration reply:**

No.	Function	Byte	Note
1	Header	0xEE	
2	Message ID	0x04	
3	Frame length	0x1C	The length of all messages is 28 bytes
4	Pitch		The corresponding byte for each function represents the corresponding channel number, such as the pitch byte is 0x01, and the yaw byte is 0x03, which represent channel 1 controlling pitch and channel 3 controlling yaw. The channel number range is 1-16. If it exceeds the range, it cannot be set successfully, and "0" represents not activating this function.
5	Yaw		
6	Visible light zoom		
7	Visible light manual focus		
8	PTZ Mode switch, One-click down		
9	One-click reset		
10	Photography		
11	Target detection and tracking		
12	PIP, black heat, white heat, color		
13	Thermography electronic zoom		
14	Laser ranging		
15	Laser night		

	vision (none)		
16	OSD-switch		
17	Reserve		
18	Reserve		
19	Reserve		
20	Reserve		
21	Reserve		
22	Reserve		
23	Reserve		
24	Reserve		
25	Reserve		
26	Reserve		
27	Reserve		
28	Sum check		1-27 byte sum, take the lower eight bits

• Example:

0xEE, 0x04, 0x1C, 0x01, 0x03, 0x02, 0x04, 0x05, 0x06, 0x00, 0x23

(Pitch is CH1, yaw is CH3, zoom is CH2, manual focus is CH4, mode switch is CH5, one click reset is CH6, and other functions are not mapped)

• The instructions for setting the S.BUS channel can be found in "S.BUS Channel Settings" in this article.

## After Sales Service

---

This chapter mainly introduces the after-sales service and the relevant statements of the scope of non-after-sales protection.

[>Click here to return to Table of contents<](#)

## After Sales Service

### After Sales Service

- General Terms of Service: This after-sales service only applies to the terminal products purchased by you for your own use and not for resale. Users should carefully follow the instructions in the product manual to use the products and follow the service procedures of the distributor.

- Product warranty period: Please confirm the specific warranty period with the dealer before purchasing this product. The warranty period of this product starts from the day after you receive the goods, and valid proof of purchase, bills, invoices and order numbers must be provided.

- Warranty parts: Pod shell, power control module, buck module, lens equipment, quick-release bracket (excluding wire); Other accessories in addition to the above parts are not covered by the warranty.

- Application for after-sales service: During the warranty period, if the product can not achieve the guaranteed function, please contact the relevant service personnel of the dealer, and explain the problem of the product in detail, in order to obtain the corresponding after-sales service; If you cannot solve your problem through telephone or remote video communication, you need to contact logistics to send the product to the designated address according to the dealer's designated service personnel for further testing, and the dealer will arrange service according to the type of warranty service enjoyed by the product;

The application for product repair requires a guarantee that the distributor or manufacturer has full, free and safe access to your equipment to provide after-sales service, and that the product or part is free from any legal restrictions preventing its replacement; If the product or part is not owned by you, obtain a license from the owner of the product or part so that the distributor or manufacturer can provide you with after-sales service.

- Replacement of products and parts: If your warranty service involves replacement of products or parts, the replaced products or parts will become the property of the distributor or manufacturer, and the replaced products or parts

will become your property, and only the original parts of the product can be replaced without modification; The replacement product or part provided by the after-sales service may not be new, but it can be guaranteed that the updated part can be in good working condition and at least equal in performance to the replaced part, and the replaced product or part enjoys the same warranty service during the remaining warranty period of the original product.

- The delivery fee shall be confirmed with the distributor in advance, and the cost of sending to the company shall be borne by the customer.
- Do not disassemble or repair yourself, otherwise you will not be able to enjoy the product warranty service.
- All final interpretation rights belong to the product developer.



Please take good care of all the purchase documents and relevant electronic documents of this product.

---

## Scope Of Non-After-Sales Guarantee

- Device wear, fragmentation, burning and other accidents caused by man-made non product quality problems.
- Damage caused by unauthorized modification, disassembly and shell opening under the guidance of unofficial instructions.
- Damage caused by improper installation, use and operation not in accordance with the instructions in the product manual.
- Repair damage caused by assembly parts by yourself.
- Damage caused by circuit modification guided by unofficial instructions, or improper use of battery packs and chargers.
- Damage caused by handling in extremely harsh environments, such as wind, rain, dust, etc.
- Damage caused by manipulation in a complex electromagnetic environment or strong interference source environment, such as mining areas, towers, high-voltage lines, substations, etc.
- Damage caused by mutual interference with other wireless devices, such as transmitter, signal transmission, WiFi signal interference.
- Damage caused by forced operation when parts are aged or damaged.
- Damage caused by reliability and compatibility issues when used with third-party components that are not certified by developers and manufacturers.
- Damage caused by insufficient discharge when the power supply is insufficient, or the voltage is too high, or when the battery with defective quality is used.
- Uninterrupted or faulty operation of the product.
- Continuous or wrong operation of the product.
- Failure or damage caused by any third party product (including all other products supplied by the distributor/manufacturer or integrated into the Product at your request).
- Change or tear off the identification label and damage the anti tear sticker.
- Unable to provide valid purchase vouchers or forge, alter behavior.

• Force majeure caused by local policies, natural disasters or other special reasons will not be able to provide after-sales service.

---

 Please take good care of all the purchase documents and relevant electronic documents of this product.

---

## Thank you for your use

---

This product is approved to leave factory as it meets the manufacturer's standard after inspection.

[>Click here to return to Table of contents<](#)